



TECH NOTE

ERPS(G.8032)
Configuration Guide



About The Tech Note

Introduction

This document includes an introduction to the Fiberroad Industrial Ethernet products family and its features, network protocol, etc. To give you a quick overview of the Fiberroad products.

Conventions

This document contains notices, figures, screen captures, and certain text conventions.

Figures and Screen Captures

This document provides figures and screen captures as an example. These examples contain sample data. This data may vary from the actual data on an installed system.

Copyright©2022 Fiberroad Technology Co., Ltd. All rights reserved. No part of this publication may be reproduced, stored in a retrieval system or transmitted in any form, be it electronically, mechanically, or by any other means such as photocopying, recording or otherwise, without the prior written permission of Fiberroad Technology Co., Ltd. (Fiberroad)

Information provided by Fiberroad is believed to be accurate and reliable. However, no responsibility is assumed by Fiberroad for its use nor for any infringements of patents or other rights of third parties that may result from its use. No license is granted by implication or otherwise under any patent rights of Fiberroad.

The information contained in this publication is subject to change without notice.

Trademarks

Fiberroad's trademarks have been identified as such. However, the presence or absence of such identification does not affect the legal status of any brand.

Units of Measurement

Units of measurement in this publication conform to SI standards and practices.

Jan 01, 2022

ERPS(G.8032) Configuration Guide

1. ERPS Overview

Ethernet Ring Protection Switching, or **ERPS**, is an effort at [ITU-T](#) under G.8032 Recommendation to provide sub-50ms protection and recovery switching for [Ethernet](#) traffic in a [ring topology](#) and at the same time ensure that there are no loops formed at the Ethernet layer. G.8032v1 supported a single ring topology and G.8032v2 supports multiple rings/ladder topology. Ethernet Rings can provide wide-area multipoint connectivity more economically due to their reduced number of links.

Each Ethernet Ring Node is connected to adjacent Ethernet Ring Nodes participating in the same Ethernet Ring, using two independent links. A ring link is bounded by two adjacent Ethernet Ring Nodes, and a port for a ring link is called a ring port. The minimum number of Ethernet Ring Nodes in an Ethernet Ring is three.

2, Ring Network Protocol

Generally, redundant links are used on an Ethernet switching network such as a ring network to provide link backup and enhance network reliability. The use of redundant links, however, may cause loops, leading to broadcast storms and rendering the MAC address table instability. As a result, communication quality deteriorates, or even communication services are interrupted. Table 1-1 describes ring network protocols supported by devices.

Ring Network Protocol	Advantage	Disadvantage	Recovery Time
STP/RSTP/MSTP	<ul style="list-style-type: none"> Applies to all L2 networks. A standard IEEE protocol that allows Fiberroad Devices to communicate with non-Fiberroad devices. 	Provides a low convergence speed on a large network, which can't meet the carrier-class reliability requirement.	RSTP: 2seconds STP: 30-50 seconds
ERPS	<ul style="list-style-type: none"> Features fast convergence speed, ensuring carrier-class reliability. A standard ITU-T protocol that allows Fiberroad devices to communicate with non-Fiberroad devices. Supports single and multi-ring topologies in ERPSv2. 	Requires complex manual configuration of many functions.	ERPS: < 50ms

Table 1-1 Ring network protocols supported by devices

3, ERPS Basic Concept

ERPS mainly includes ERPS ring, node, port role and port status

3.1 ERPS Instance

ERPS instance is formed by the same instance ID, control VLAN and interconnected switches.

3.2 Control Channel

The Control channel is the transmission VLAN of ERPS protocol, and the protocol packet will carry the corresponding VLAN tag.

3.3 RPL

RPL(Ring Protection Link) is, Link designated by a mechanism that is blocked during the idle state to prevent loop on the bridged ring.

3.4 ERPS Ring

ERPS ring is ERPS basic unit. It is composed of a set of the same control VLAN and the interlinked L2 switch equipment.

3.5 Node

The L2 switch added in the ERPS ring is called nodes. Each node can not be added to more than two ports in the same ERPS ring. The nodes are divided into RPL Owner, Neighbor, and Ring Node.

3.6 Port Role

In ERPS, port roles include RPL Owner, Neighbor and Common:

- 1) **RPL Owner:** An ERPS ring has only one RPL Owner port configured by the user and it prevents loops in the ERPS ring via blocking the RPL Owner port. The node that owns the RPL Owner port becomes the RPL Owner node.
- 2) **RPL Neighbour:** An ERPS ring has only one RPL Neighbor port configured by the user and it must be a port connected to the RPL Owner port. If the network is normal, it will block together with the RPL Owner port to prevent loops in the ERPS ring. The node with the RPL Neighbor port becomes the RPL Neighbor node.
- 3) **Ring Node:** The common port. The ports except for RPL owner and Neighbor port are Ring Node ports. If the node has only the common port, this node will become the Ring node.

3.7 Port Status

In the ERPS ring, the port status of the ERPS protocol is divided into two types.

- 1) **Forwarding:** In Forwarding status, the port forwards user traffic and receives / forwards R-APS packets. Moreover, it forwards R-APS packets from other nodes.
- 2) **Blocking:** In the Blocking status, a port in the blocking status does not participate in frame forwarding and also discards frames received from the attached network segment. However, ERPS messages are forward.

3.8 ERPS operating mode

Word mode includes: Revertive and Non-revertive

- 1) **Revertive:** When the link fails, the RPL link is in the release protections state and RPL link is re-protected after the faulty link is restored to prevent loops.
- 2) **Non-revertive:** After the fault is rectified, the faulty node remains faulty(without

entering forwarding) and the RPL link remains in the release protection state.

4 ERPS Operation

4.1 ERPS Components

ERPS Instance

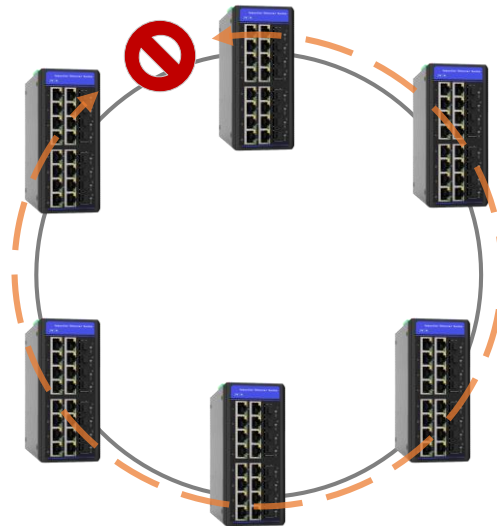

Instance is a logical ring that running over physical ring, that composed of a set of VLANs. Each node contains an instance. It is made up of:

- ❖ Two ERPS ring ports
- ❖ A control VLAN that carries Ring-Automatic Protection Switching(R-APS) messages.
- ❖ One or more Protected Data VLANs that the instance protects when the ring fails.

4.2 ERPS ring ports

These are the physical interface ports or interface Link Aggregation Groups (LAGs) that are used by the instance. In the major ring case, all nodes are required to have two ERPS ring ports. Traditionally, these are referred to as East and West ring ports.

4.3 RAPS channel VLAN(Control VLAN)

R-APS messages are carried over a channel. In G.8032, this channel is implemented using a VLAN. Each ERP instance uses a tag-based VLAN called the raps-channel for sending and receiving R-APS messages. All the nodes in the ring are required to use this raps-channel VLAN, and this VLAN must have the ERP ring ports as members. The function of the R-APS VLAN is to monitor the ring and maintain its operational functions. The R-APS VLAN carries no user data.

R-APS messages flow through the ring to control its protection switching behavior. Each node along the path will receive the R-APS message on the raps-channel VLAN and copy it for local processing.

It will also attempt to forward the original version at L2 switching speed to its other ring port. If the raps-channel VLAN on the other ring port is blocked, then the R-APS

message is not forwarded to the other nodes.

The raps-channel control VLAN is blocked from being forwarded to other nodes at the same place the protected data VLANs are blocked from being forwarded.

Notes: Sub-rings without a virtual channel are an exception which is discussed below. In this case, the raps-channel VLAN is not blocked from being forwarded even though the protected data VLANs are blocked.

The node that actually generates the R-APS messages will always send over both of its ring ports regardless of whether or not the raps-channel VLAN is being blocked on its ring ports. Similarly, R-APS messages will be received and processed regardless of whether or not the raps-channel VLAN is being blocked on its ring ports. Below is the R-APS Message Format.

Request/State	Reserved 1	RB	DNF	BPR	Status Reserved	Node ID (6 octets)
Node ID						
Reserved 2(24 octets)						
...						

Specific Information (32 octets) is below:

Request/Status(4bits) - '1101' = FS , '1110' = Event, '1011' = SF, '0111' = MS, '0000' = NR, Other = Future

Status - RB (1bit) - Set when RPL is blocked (used by RPL Owner in NR)

Status - DNF (1bit) - Set when FDB Flush is not necessary

NodeID (6octets) - MAC address of message source node (Informational)

Reserved1(4bits), Status Reserved(6bits), Reserved2(24octets)

Notes: RAPS (Ring Auto Protection Switch) virtual channel: In the intersecting ring, the intersecting node between, used to transmit sub-ring protocol packets, but not belonging to the sub-ring is called the RAPS virtual channel of the sub-ring.

4.4 Protected Data VLAN

Each ERP instance protects one or more data carrying VLANs (called data traffic). All the nodes in the ring are required to have the same protected VLANs. The protected VLANs should have the ERPS ring ports as members.

RPL Owner

The RPL provides the blocking of traffic under normal operating conditions, thus preventing loops. The RPL consists of an Owner on one end, and a Neighbor on the other end. It is the Owner that provides the main control for protection switching. Under normal operating conditions both ends of the RPL perform a block. However,

the Owner generates R-APS No Request RPL-Blocked(NR,RB) messages continuously and is the one in charge of the RPL's blocking and forwarding states.

Under normal operation, when there are no failures, the RPL-Owner generates R-APS(NR,RB) messages. It periodically sends these, every 5 seconds, over both of its ring ports. These messages indicate which of its East or West ring ports is being blocked. Each node along the way receives the R-APS, recording the Node-id and Block Port Reference (BPR) in the message. This is used to detect a topology change.

Notes: Configuring a G.8032 ring without an RPL-Owner is never recommended. While the G.8032 protocol can operate without an RPL-Owner, as other nodes in the ring are allowed to send R-APS messages and block traffic under both normal and failed conditions, the RPL-Owner provides predictability as to where the ring block will occur under normal conditions. The RPL-Owner is also needed for revertive operations.

4.5 ERPS Operating Principle

Normal Status

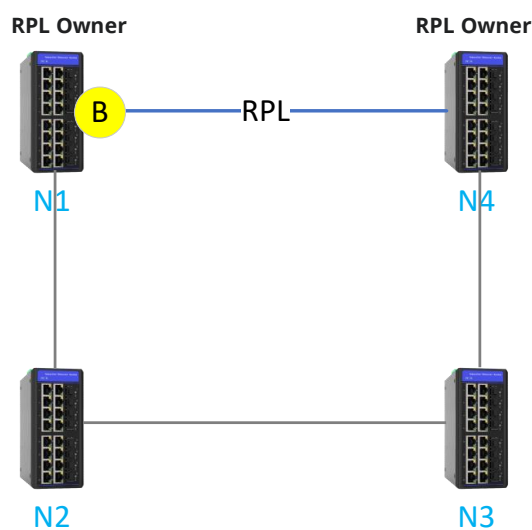

Figure 2 Normal Status

B Blocked Port

- (1) All nodes are connected in a ring on the physical topology
- (2) The loop protection protocol blocks the RPL link to ensure that it will not form a loop. As shown in the figure above, Node1 and Node4, The link is RPL link;
- (3) Perform fault detection on each link between adjacent nodes.

Failure Occurs

RPL Owner

RPL Owner

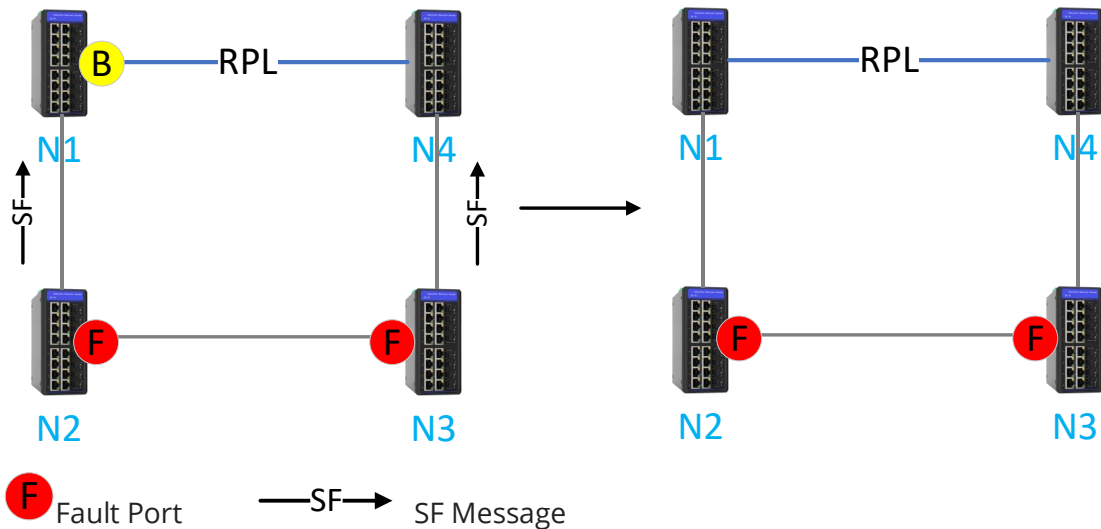

- (1) The node adjacent to the fault performed the fault problem once and used RAPS (SF) messages to other nodes on the ring Point to report the failure, as shown in the figure above, if there is a failure between Node2 and Node3, then Node2 and Node3 are waiting. After a certain occurrence, you will encounter troubles, and send RAPS(SF) to the netizens respectively;
- (2) The RAPS (SF) message triggers the RPL owning node to open the RPL port. The RAPS (SF) message also triggers all node updates New respective MAC table entries, and then the node enters the protection state.

Failure Recovery

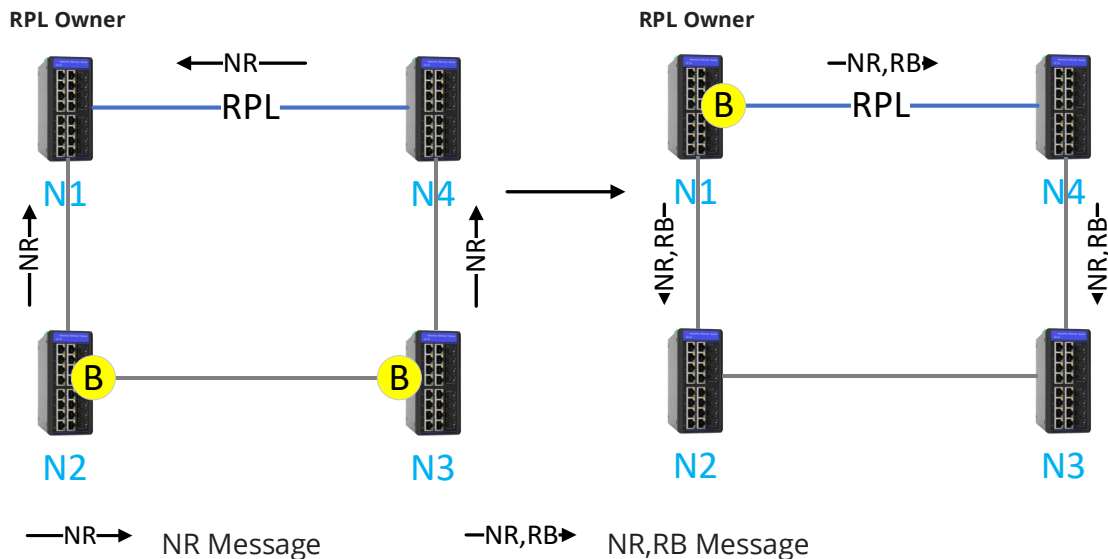

- (1) When the fault is recovery, the adjacent nodes of the fault continue to remain blocked and send RAPS (NR) messages to indicate that there isn't local failure;
- (2) After receiving the R-APS(NR) message, other nodes also enter the pending state. If it is the RPL Owner node, it starts the WTR timer after receiving the first R-APS(NR) message.
- (3) When the WTR timer of the RPL Owner node expires, the RPL Owner node sends R-APS(NR,RB, DNF) and blocks the RPL port, and then sends R-APS(NR,RB)

- message. The loop state of the node becomes idle. (3) When the WTR timer is exhausted, the RPL Owner node blocks the RPL Port and sends a RAPS (NR, RB, DNF) message;
- (4) When the RPL neighbour node receives the R-APS(NR,RB) message, the RPL port is blocked, and the node ring enters an idle state.
 - (5) After receiving the R-APS(NR-RB) message, other links stop actively sending protocol packets and enter the idle state.

4.6 Revertive and Non-Revertive Operations

G.8032 also provides for revertive operations. Once the failure clears and after a waiting time of typically 5 minutes, the ring switches back to its normal mode of operation. G.8032 also provides for a non-revertive operation, where once the failure abates, a protection switch back to the normal state does not occur. In this case, the links where the failure had occurred remain blocked and the RPL remains unblocked. A clear command, described below, is provided for you to control whether a revertive or non-revertive operation is allowed.

1. **REVERTIVE** In the ideal case, the link between the Root Node and the Root Neighbor is blocked. In case of Signal Failure or operator commands like Forced Switch or Manual Switch occurs, the aforementioned link gets unblocked in order to steer the traffic. Upon recovery, the same link should get blocked to prevent the formation of a loop. In the Revertive mode of operation, upon the recovery of the failed link, the Ring Protection Link gets blocked automatically.

2. **NON-REVERTIVE** In Non-Revertive mode, upon the recovery of the failed link or operator commands, the Ring Protection Link doesn't get blocked automatically. The failed link or the link upon which the operator command was issued remains in the blocked state, thereby preventing a loop formation. The advantage behind this here is to avoid unnecessary toggling between states. This toggling may necessitate flushing of learnt MAC address on the ports.

Notes: When revertive operations are used, the ring will not revert back immediately. Reversion does not start until the wait-to restore has expired, which is 5 minutes by default.

4.7 Forced Switch(FS) and Manual Switch(MS)

Forced Switch (FS) is a command that can be issued to force a ring to switch. The command is issued at a given node and a given interface on the ring. This results in a block being applied at that interface and an unblock on the opposite interface, and an R-APS Forced Switch (FS) message to flow around the ring. This will result in the RPL becoming unblocked. Any other nodes that had a block previously will also unblock when they get this message. FDB flushes also occur along the way.

Notes: Forced Switch(FS) commands can be issued at multiple locations along the ring. However, doing so may result in the ring becoming segmented. The Manual Switch(MS) command is nearly identical to a forced Switch(FS) command except that only one Manual Switch(MS) command can be issued on the ring. It also has a lower priority than a Forced Switch(FS) command when a node has many requests that it needs to process at the same time.

To undo this operation, use the clear command at the same node. This will cause the clearing node to unblock any block it had previously applied. It will also send a R-APS No Request(NR) message, which in turn will cause the RPL to become blocked again.

4.8 ERPS State

There are five states in the ERPS protocol

1. IDLE State

This state represents there is no signal fail or any administrative command (Forced/Manual Switch) prevailing over the ring. The RPL(Ring Protection Link) is blocked(Doesn't carry data traffic, but Tx/Rx the APS PDU's)

2. Protection State

This state represents the Signal Fail condition in the Ring. Normally the RPL is unblocked to steer the traffic in the ring. When more than one Signal Fail occurs in the Ring, it results in segmenting the ring. Traffic flow is disturbed.

3. Pending State

This state occurs when the Signal Fail condition is revoked by the issuer, and the RPL is not still blocked. Generally, the Root node after receiving the No Request Message (indication of No Signal Fail condition) waits till the Wait-To-Restore time to block the RPL. This is the condition where the Ring goes into Pending State. It also occurs during the waiting period in wait-to-block after revoking forced/manual switch.

4. Forced Switch

This is management triggered state. When an administrator needs to make a port down which is participating in the ring, this management entity will come into action. When a Forced Switch object is issued on the port, the port goes down and the APS PDU gets propagated around the ring indicating the status. When the clear management object is set on the port, this Forced Switch is revoked.

Notes: This has higher precedence to Signal Fail status. So even when some node is facing signal Fail, this will supersede it.

5 Manual Switch

Similar to Forced Switch, the Manual Switch is also management triggered. The difference is that it has a lower priority compared to Forced Switch. When there is a Forced Switch or Signal Fail Prevailing over the ring, this condition is rejected by the ERPS process. The clear management object will revoke the Manual Switch state.

4.9 Timers

There are four timers involved in the ERPS protocol. The last two timers are the delay timers and are employed only on the Root Node.

4.9.1 Hold-off Timer

After the expiry of the Hold-off timer, the problem in the physical layer is communicated to the ERPS Control Process. In example it defers the indication of Signal Fail on one of the ring ports for a period of configured Hold-off time.

4.9.2 Guard Timer

This timer is used to prevent the outdated messages from interfering with the ERPS State machine of that ring. When the node clear's its Signal Fail condition, the guard timer is started. When the guard timer is running, it rejects all the APS PDU except the 'event' message. This timer is used to prevent any latent information which is arriving from the far end of the ring.

4.9.3 Wait-To-Block Timer

As mentioned earlier, the Wait-to-Block timer is employed at that Root Node. This timer is used when the ring recovers from the operator command (Forced Switch or Manual Switch). When the Wait-to-Block Timer expires the Ring Protection Link is blocked.

4.9.4 Wait-To-Restore Timer

When the ring recovers the Signal Failure the Root Node starts the Wait-to-Restore Timers. Upon expiry, the Ring Protection Link is blocked. If it is a revertive mode of operation, it is blocked at once. In case of non-revertive it is blocked when the operator command "clear" is given.

4.10 ERPS Messages

Different types of ERPS Messages are

1. **SIGNAL FAIL (SF)** - This message denotes failure of the Ring Link.
2. **NO REQUEST (NR)** - This indicates clearing of the failure in the Ring Link
3. **NO REQUEST ROOT BLOCKED (NR, RB)** - This is transmitted by the Root node, denoting that, the Ring Protection Link is blocked.
4. **FORCED SWITCH (FS)** - This message indicates that Forced Switch has occurred.
5. **MANUAL SWITCH (MS)** - This message indicates that Manual Switch has occurred.

4.11 ERPSv1 and ERPSv2

ERPSv1 and ERPSv2 are currently available. ERPSv1 was released by ITU-T in June, 2008, and ERPSv2 was released August, 2010. ERPSv2, fully compatible with ERPSv1, provides enhanced functions. Table 1-2 compares ERPSv1 and ERPSv2.

Function	ERPSv1	ERPSv2
Ring Type	Supports single rings only	Supports single rings and multi-rings. A multi-ring topology comprises major rings and sub-rings.
Port Role	Supports the ring protection link(RPL)	Supports the RPL owner port, RPL neighbor port,

	owner port and ordinary ports.	and ordinary ports
Topology change notification	Not supported	Supported
R-APS PDU transmission mode on sub-rings	Not supported	Supported
Revertive and non-revertive switching	Supports revertive switching by default and does not support non-revertive switching or switching mode configuration.	Supported
Manual port blocking	Not supported.	Supports forced to switch(FS) and manual switch(MS)

Table 1-2 Comparison between ERPSv1 and ERPSv2

5 ERPS Configuration bases on WebGUI

5.1 ERPS Global Setting

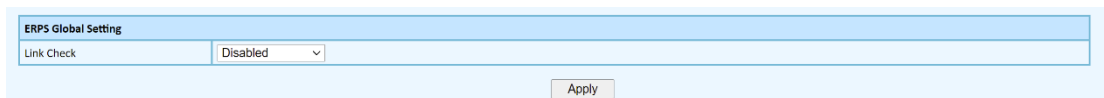

Figure 5.1.1 ERPS Global Setting

Configuration Step

1. Select [Advanced / ERPS / Global Setting] in the navigation bar and enter the ERPS [Global Setting] interface

Notes: There is a way to check port link by sending packets. If the optical is used as the ring port, it is recommended to 'Disable' the link check. If the ethernet port is the ring port, you may decide whether to 'Enable' it in following two cases:

- (1) Please enable it if the switching time demand is very high. Although the switching time has been improved, the drawback is that the packet mechanism will occupy bandwidth.
- (2) Please disable it if the switching time requirement is not high.

5.2 ERPS Ring Configuration Interface

Ring Adding	
Ring ID	<input type="text" value=""/> <1-255>
Ring Type	major-ring ▾
Node Type	transfer ▾
Protocol Vlan	<input type="text" value=""/> <1-4094>
East Port	GE/1 ▾
West Port	GE/1 ▾
RPL Port	none ▾
Belong Major ring	none
Virtual Channel	with ▾
WTR Timer	<input type="text" value="1"/> <1-12> minutes Default:1 minutes, Step is 1 minutes
Guard Timer	<input type="text" value="500"/> <10-2000> milliseconds Default:500 milliseconds, Step is 10 milliseconds
HoldOff Timer	<input type="text" value="0"/> <0-10000> milliseconds Default:0 milliseconds, Step is 100 milliseconds
<input type="button" value="Apply"/> <input type="button" value="Cancel"/>	

Figure 5.2 ERPS Ring Configuration Interface

Configuration Step

1.Select [Advanced / ERPS / Ring Setting] in the navigation bar and enter the ERPS [Ring Setting] interface

Item	Description	Notes
Ring ID	Ring Adding ID <1-255>	
Ring Type	Major-ring / Sub-ring	
Node Type	<p>Transfer: Forward both service packets and protocol packets</p> <p>rpl-owner: Responsible for blocking traffic over the RPL so that no loops are formed in the Ethernet traffic. There can be only one RPL owner in a ring.</p> <p>rpl-neighbour: An Ethernet ring node adjacent to the RPL. It is responsible for blocking its end of the RPL under normal conditions. This node type is optional and prevents RPL usage when protected.</p>	
Protocol VLAN	Adding ring ERPS protocol VLAN	
East Port	A Ring port created on this node	
West Port	Another ring port created on the node	
RPL Port	*Port on an RPL Link	
Belong Major Ring		
Virtual Channel		
WTR Timer	<1-12> minutes, Default: 1 minutes, Step 1 minutes	

Guard Timer	<10-2000>milliseconds Default:500 milliseconds, Step is 10 milliseconds
HoldOff Timer	<0-10000>milliseconds Default:0 milliseconds, Step is 100 milliseconds

5.2.2 Click [Modify], Enter Ring Modifying interface

Ring Modify	
Ring ID	1 <1-255>
Ring Type	major-ring ▾
Virtual Channel	with ▾
WTR Timer	1 <1-12> minutes Default:5 minutes, Step is 1 minutes
Guard Timer	500 <10-2000> milliseconds Default:500 milliseconds, Step is 10 milliseconds
HoldOff Timer	0 <0-10000> milliseconds Default:0 milliseconds, Step is 100 milliseconds
<input type="button" value="Apply"/> <input type="button" value="Cancel"/>	

Figure 5.2 .2 ERPS Ring Modify Interface

5.2.3 Click [Switching], Enter Ring traffic switching configuration interface

Ring Switching	
Ring ID	1
Ring Type	major-ring ▾
East Port	GE/1 ▾
West Port	GE/3 ▾
Switching Mode	clear ▾
<input type="button" value="Apply"/> <input type="button" value="Cancel"/>	

Figure 5.2.3 ERPS Ring traffic Switching Interface

Notes: In addition, the ring switching is divided into FS (forced switching) and MS (manual switching). The actual operation of switching is to set the port specified for switching to the block state, and then clear the forwarding table. In this way, relative to this port, The direction of traffic is reversed; secondly, ERPS operations are in sequence. When there are events with high priority, those with low priority will not be corresponding. The priority is shown in Figure 5.2.3, According to the figure, the priority of clear operation level is the highest, no matter what kind of event occurs at present, as long as the clear operation is performed, the current switching configuration will be cleared; the FS operation is the second; SF means fault, local SF means local fault, R-APS(SF) means receiving faults from other places, SF has higher priority than SF (including local SF and R-APS(SF)), Therefore, even if the current system is in a fault state, if the FS operation is issued, the system will still execute it accordingly; after the MS is in the SF and R-APS(MS) (R-APS(MS) indicates that another device has performed the MS operation) , so if the system is in a fault state, or other devices in the ring perform MS operations, the

currently newly issued MS operations will not be performed. The latter events are state machine events, and there is no need to pursue them here.

Request/State and Status	Type	Priority
Clear	Local	Highest
FS	Local	
R-APS(FS)	Remote	
Local SF*	Local	
Local Clear SF	Local	
R-APS(SF)	Remote	
R-APS(MS)	Remote	
MS	Local	
WTR Expires	Local	
WTR Running	Local	
WTB Expires	Local	
WTB Running	Local	
R-APS(NR, RB)	Remote	
R-APS(NR)	Remote	Lowest

*If an Ethernet ring node is in the Forced Switch State, Local SF is ignored

Figure 5.2.3 ERPS traffic switching configuration interface

5.2.4 ERPS Ring Information

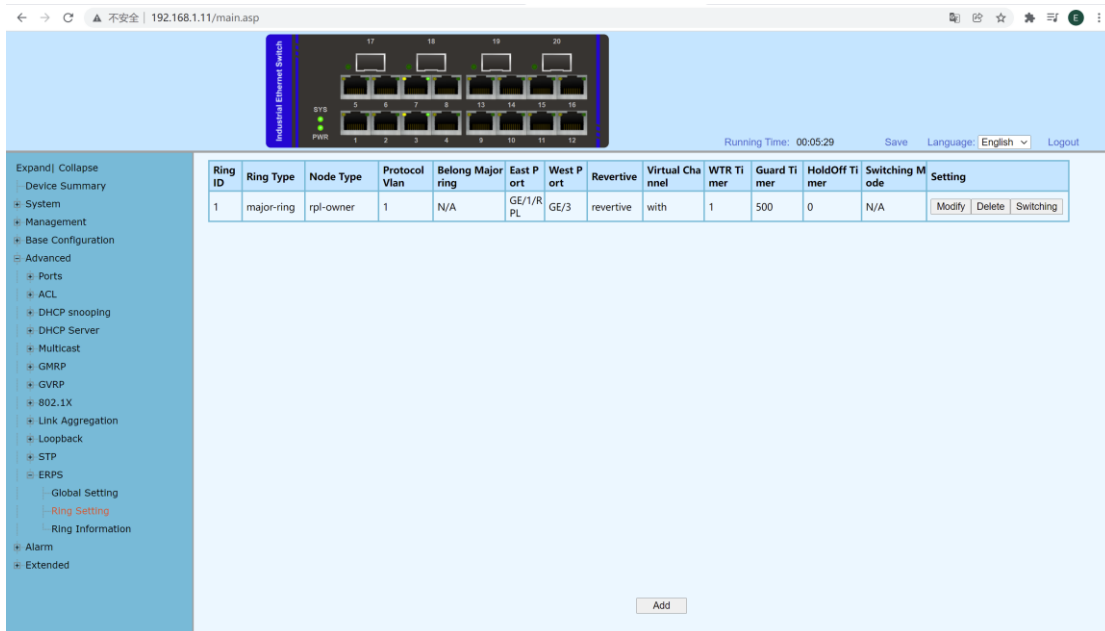

6 Configuration Case

6.1 Single Ring

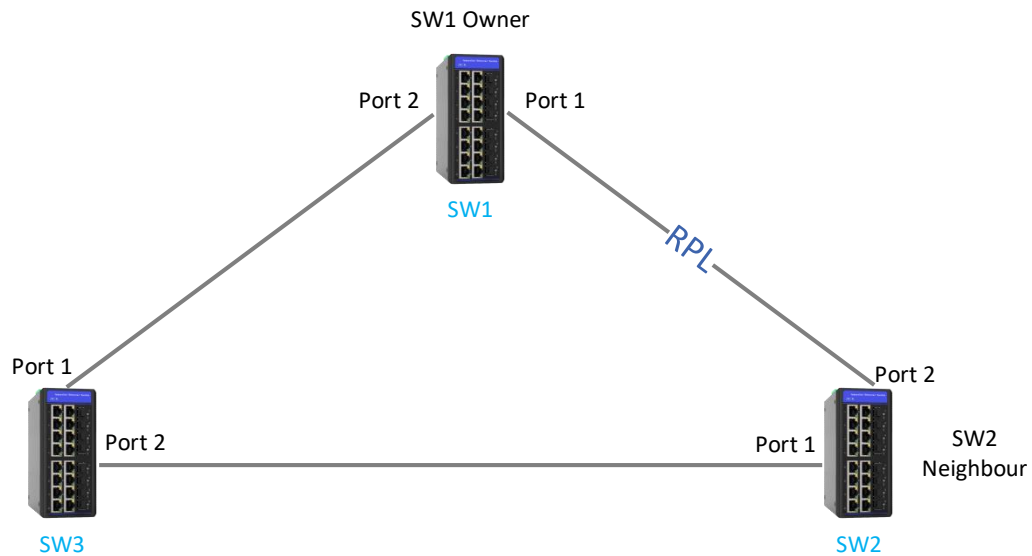

According to the topology shown in the figure, Firstly configure the VLAN. All Ring ports need to allow the protocol VLAN to pass through. The VLAN configuration will not be repeated here. The ring configuration as follows:

SW1 WEB configuration as shown:

Ring Adding	
Ring ID	1 <1-255>
Ring Type	major-ring
Node Type	rpl-owner
Protocol Vlan	1 <1-4094>
East Port	GE/1
West Port	GE/2
RPL Port	East Port
Belong Major ring	none
Virtual Channel	with
WTR Timer	1 <1-12> minutes Default:1 minutes, Step is 1 minutes
Guard Timer	500 <10-2000> milliseconds Default:500 milliseconds, Step is 10 milliseconds
HoldOff Timer	0 <0-10000> milliseconds Default:0 milliseconds, Step is 100 milliseconds
<input type="button" value="Apply"/> <input type="button" value="Cancel"/>	

SW2 WEB configuration as shown:

Ring Adding	
Ring ID	1 <1-255>
Ring Type	major-ring
Node Type	rpl-neighbou
Protocol Vlan	1 <1-4094>
East Port	GE/1
West Port	GE/2
RPL Port	West Port
Belong Major ring	none
Virtual Channel	with
WTR Timer	1 <1-12> minutes Default:1 minutes, Step is 1 minutes
Guard Timer	500 <10-2000> milliseconds Default:500 milliseconds, Step is 10 milliseconds
HoldOff Timer	0 <0-10000> milliseconds Default:0 milliseconds, Step is 100 milliseconds
<input type="button" value="Apply"/> <input type="button" value="Cancel"/>	

SW3 WEB configuration as shown:

Ring Adding	
Ring ID	1 <1-255>
Ring Type	major-ring
Node Type	transfer
Protocol Vlan	1 <1-4094>
East Port	GE/1
West Port	GE/2
RPL Port	none
Belong Major ring	none
Virtual Channel	with
WTR Timer	1 <1-12> minutes Default:1 minutes, Step is 1 minutes
Guard Timer	500 <10-2000> milliseconds Default:500 milliseconds, Step is 10 milliseconds
HoldOff Timer	0 <0-10000> milliseconds Default:0 milliseconds, Step is 100 milliseconds
<input type="button" value="Apply"/> <input type="button" value="Cancel"/>	

6.3 Double Ring Configuration

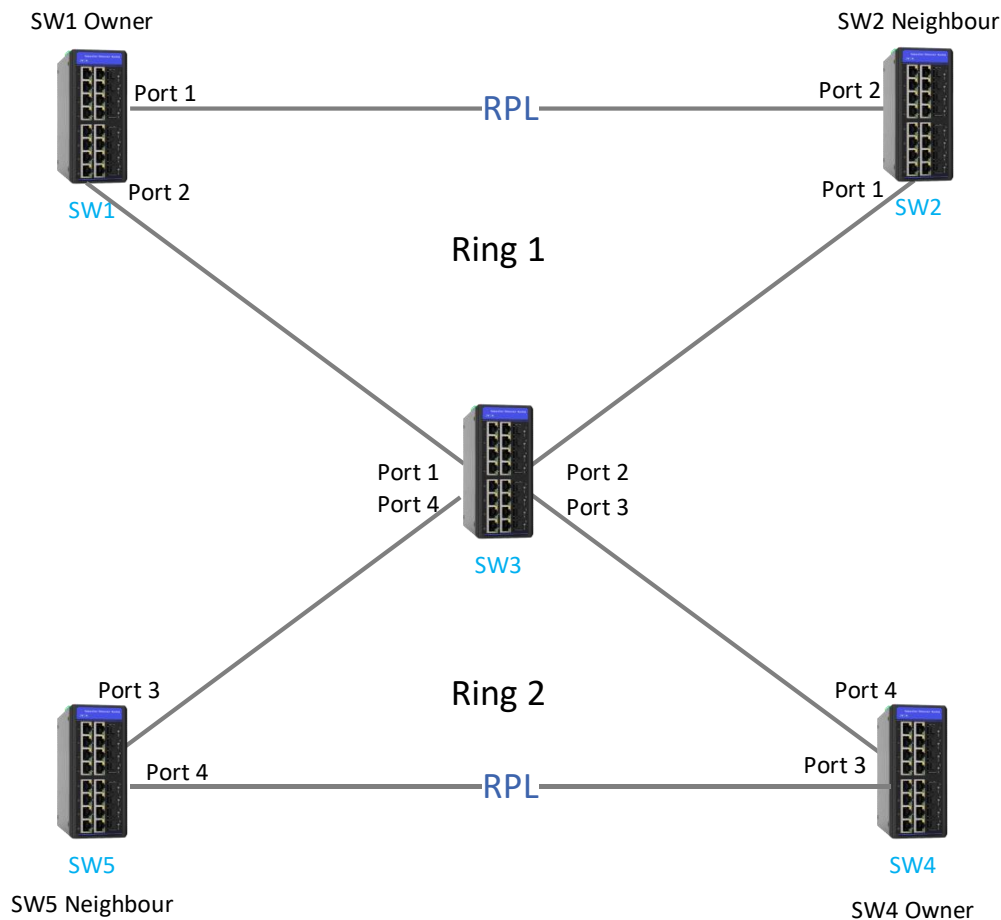

According to the topology shown in the figure, Configure the VLAN first. The Port of the corresponding ring must allow the protocol VLAN of the corresponding ring to pass through without future elaboration, the tangential ring configuration as follows:

SW1 WEB configuration as shown:

Ring Adding	
Ring ID	1 <1-255>
Ring Type	major-ring
Node Type	rpl-owner
Protocol Vlan	1 <1-4094>
East Port	GE/1
West Port	GE/2
RPL Port	East Port
Belong Major ring	none
Virtual Channel	with
WTR Timer	1 <1-12> minutes Default:1 minutes, Step is 1 minutes
Guard Timer	500 <10-2000> milliseconds Default:500 milliseconds, Step is 10 milliseconds
HoldOff Timer	0 <0-10000> milliseconds Default:0 milliseconds, Step is 100 milliseconds
<input type="button" value="Apply"/> <input type="button" value="Cancel"/>	

SW2 WEB configuration as shown:

Ring Adding	
Ring ID	<input type="text" value="1"/> <1-255>
Ring Type	major-ring ▼
Node Type	rpl-neighbou ▼
Protocol Vlan	<input type="text" value="1"/> <1-4094>
East Port	GE/1 ▼
West Port	GE/2 ▼
RPL Port	West Port ▼
Belong Major ring	none
Virtual Channel	with ▼
WTR Timer	<input type="text" value="1"/> <1-12> minutes Default:1 minutes, Step is 1 minutes
Guard Timer	<input type="text" value="500"/> <10-2000> milliseconds Default:500 milliseconds, Step is 10 milliseconds
HoldOff Timer	<input type="text" value="0"/> <0-10000> milliseconds Default:0 milliseconds, Step is 100 milliseconds
<input type="button" value="Apply"/> <input type="button" value="Cancel"/>	

SW3 (Ring 1) WEB configuration as shown:

Ring Adding	
Ring ID	<input type="text" value="1"/> <1-255>
Ring Type	major-ring ▼
Node Type	transfer ▼
Protocol Vlan	<input type="text" value="1"/> <1-4094>
East Port	GE/1 ▼
West Port	GE/2 ▼
RPL Port	none ▼
Belong Major ring	none
Virtual Channel	with ▼
WTR Timer	<input type="text" value="1"/> <1-12> minutes Default:1 minutes, Step is 1 minutes
Guard Timer	<input type="text" value="500"/> <10-2000> milliseconds Default:500 milliseconds, Step is 10 milliseconds
HoldOff Timer	<input type="text" value="0"/> <0-10000> milliseconds Default:0 milliseconds, Step is 100 milliseconds
<input type="button" value="Apply"/> <input type="button" value="Cancel"/>	

SW3 (Ring 2) WEB configuration as shown:

Ring Adding	
Ring ID	2 <1-255>
Ring Type	major-ring
Node Type	transfer
Protocol Vlan	2 <1-4094>
East Port	GE/3
West Port	GE/4
RPL Port	none
Belong Major ring	none
Virtual Channel	with
WTR Timer	1 <1-12> minutes Default:1 minutes, Step is 1 minutes
Guard Timer	500 <10-2000> milliseconds Default:500 milliseconds, Step is 10 milliseconds
HoldOff Timer	0 <0-10000> milliseconds Default:0 milliseconds, Step is 100 milliseconds
<input type="button" value="Apply"/> <input type="button" value="Cancel"/>	

SW4 WEB configuration as shown:

Ring Adding	
Ring ID	2 <1-255>
Ring Type	major-ring
Node Type	rpl-owner
Protocol Vlan	2 <1-4094>
East Port	GE/3
West Port	GE/4
RPL Port	East Port
Belong Major ring	none
Virtual Channel	with
WTR Timer	1 <1-12> minutes Default:1 minutes, Step is 1 minutes
Guard Timer	500 <10-2000> milliseconds Default:500 milliseconds, Step is 10 milliseconds
HoldOff Timer	0 <0-10000> milliseconds Default:0 milliseconds, Step is 100 milliseconds
<input type="button" value="Apply"/> <input type="button" value="Cancel"/>	

SW5 WEB configuration as shown:

Ring Adding	
Ring ID	2 <1-255>
Ring Type	major-ring
Node Type	rpl-neighbour
Protocol Vlan	2 <1-4094>
East Port	GE/3
West Port	GE/4
RPL Port	West Port
Belong Major ring	none
Virtual Channel	with
WTR Timer	1 <1-12> minutes Default:1 minutes, Step is 1 minutes
Guard Timer	500 <10-2000> milliseconds Default:500 milliseconds, Step is 10 milliseconds
HoldOff Timer	0 <0-10000> milliseconds Default:0 milliseconds, Step is 100 milliseconds
<input type="button" value="Apply"/> <input type="button" value="Cancel"/>	

6.4 Intersecting Ring Configuration

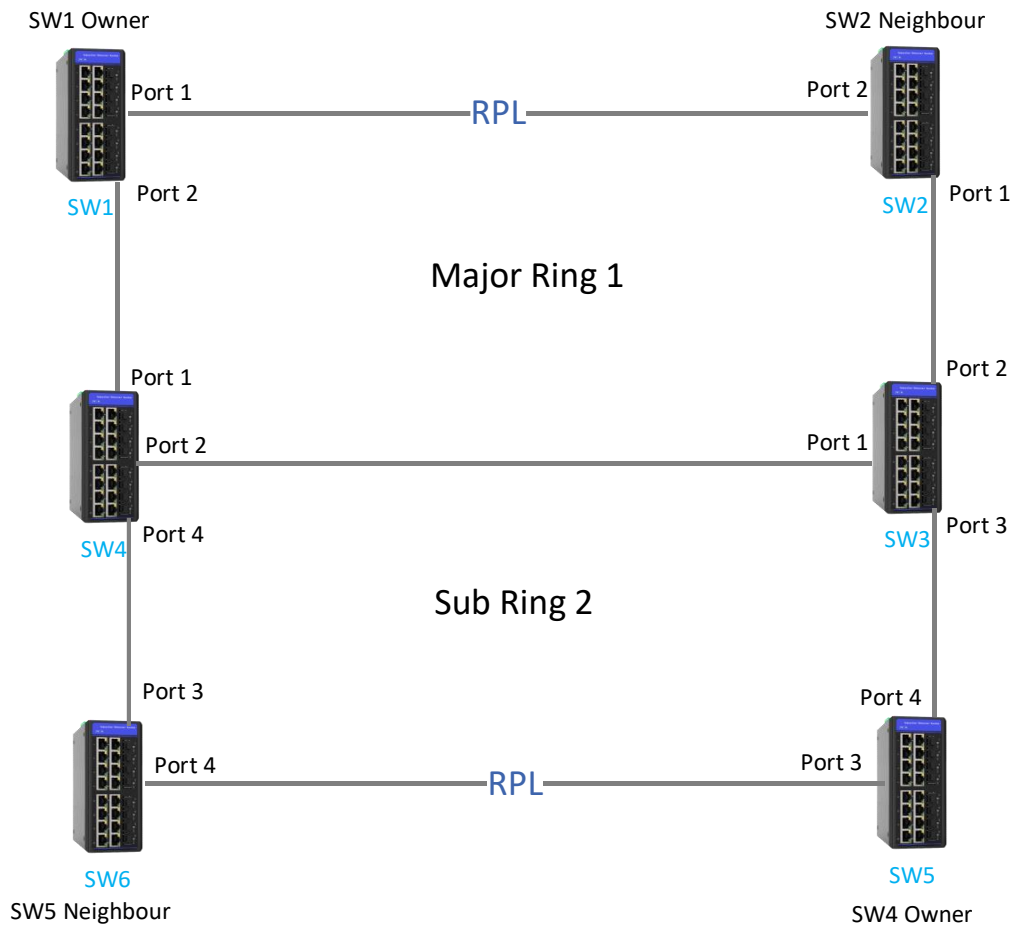

According to the topology shown in the figure, Configure the VLAN first. The Port of the corresponding ring must allow the protocol VLAN of the corresponding ring to pass through, The ring port also needs to allow the protocol VLAN of the sub-ring to pass through. The VLAN configuration will not be repeated here.

SW1 WEB configuration as shown:

Ring Adding	
Ring ID	<input type="text" value="1"/> <1-255>
Ring Type	major-ring ▼
Node Type	rpl-owner ▼
Protocol Vlan	<input type="text" value="1"/> <1-4094>
East Port	GE/1 ▼
West Port	GE/2 ▼
RPL Port	East Port ▼
Belong Major ring	none
Virtual Channel	with ▼
WTR Timer	<input type="text" value="1"/> <1-12> minutes Default:1 minutes, Step is 1 minutes
Guard Timer	<input type="text" value="500"/> <10-2000> milliseconds Default:500 milliseconds, Step is 10 milliseconds
HoldOff Timer	<input type="text" value="0"/> <0-10000> milliseconds Default:0 milliseconds, Step is 100 milliseconds
<input type="button" value="Apply"/> <input type="button" value="Cancel"/>	

SW2 WEB configuration as shown:

Ring Adding	
Ring ID	<input type="text" value="1"/> <1-255>
Ring Type	major-ring ▼
Node Type	rpl-neighbour ▼
Protocol Vlan	<input type="text" value="1"/> <1-4094>
East Port	GE/1 ▼
West Port	GE/2 ▼
RPL Port	West Port ▼
Belong Major ring	none
Virtual Channel	with ▼
WTR Timer	<input type="text" value="1"/> <1-12> minutes Default:1 minutes, Step is 1 minutes
Guard Timer	<input type="text" value="500"/> <10-2000> milliseconds Default:500 milliseconds, Step is 10 milliseconds
HoldOff Timer	<input type="text" value="0"/> <0-10000> milliseconds Default:0 milliseconds, Step is 100 milliseconds
<input type="button" value="Apply"/> <input type="button" value="Cancel"/>	

SW3(Major Ring 1) WEB configuration as shown:

Ring Adding	
Ring ID	1 <1-255>
Ring Type	major-ring
Node Type	transfer
Protocol Vlan	1 <1-4094>
East Port	GE/1
West Port	GE/2
RPL Port	none
Belong Major ring	none
Virtual Channel	with
WTR Timer	1 <1-12> minutes Default:1 minutes, Step is 1 minutes
Guard Timer	500 <10-2000> milliseconds Default:500 milliseconds, Step is 10 milliseconds
HoldOff Timer	0 <0-10000> milliseconds Default:0 milliseconds, Step is 100 milliseconds
<input type="button" value="Apply"/> <input type="button" value="Cancel"/>	

SW3(Sub Ring 2) WEB configuration as shown:

Ring Adding	
Ring ID	2 <1-255>
Ring Type	sub-ring
Node Type	transfer
Protocol Vlan	2 <1-4094>
East Port	none
West Port	GE/3
RPL Port	none
Belong Major ring	1
Virtual Channel	with
WTR Timer	1 <1-12> minutes Default:1 minutes, Step is 1 minutes
Guard Timer	500 <10-2000> milliseconds Default:500 milliseconds, Step is 10 milliseconds
HoldOff Timer	0 <0-10000> milliseconds Default:0 milliseconds, Step is 100 milliseconds
<input type="button" value="Apply"/> <input type="button" value="Cancel"/>	

SW4 (Major Ring 1) WEB configuration as shown:

Ring Adding	
Ring ID	1 <1-255>
Ring Type	major-ring
Node Type	transfer
Protocol Vlan	1 <1-4094>
East Port	GE/1
West Port	GE/2
RPL Port	none
Belong Major ring	none
Virtual Channel	with
WTR Timer	1 <1-12> minutes Default:1 minutes, Step is 1 minutes
Guard Timer	500 <10-2000> milliseconds Default:500 milliseconds, Step is 10 milliseconds
HoldOff Timer	0 <0-10000> milliseconds Default:0 milliseconds, Step is 100 milliseconds
<input type="button" value="Apply"/> <input type="button" value="Cancel"/>	

SW4 (Sub Ring 2) WEB configuration as shown:

Ring Adding	
Ring ID	2 <1-255>
Ring Type	sub-ring
Node Type	transfer
Protocol Vlan	2 <1-4094>
East Port	none
West Port	GE/4
RPL Port	none
Belong Major ring	1
Virtual Channel	with
WTR Timer	1 <1-12> minutes Default:1 minutes, Step is 1 minutes
Guard Timer	500 <10-2000> milliseconds Default:500 milliseconds, Step is 10 milliseconds
HoldOff Timer	0 <0-10000> milliseconds Default:0 milliseconds, Step is 100 milliseconds
<input type="button" value="Apply"/> <input type="button" value="Cancel"/>	

SW5 (Sub Ring 2) WEB configuration as shown:

Ring Adding	
Ring ID	2 <1-255>
Ring Type	sub-ring
Node Type	rpl-owner
Protocol Vlan	2 <1-4094>
East Port	GE/3
West Port	GE/4
RPL Port	East Port
Belong Major ring	none
Virtual Channel	with
WTR Timer	1 <1-12> minutes Default:1 minutes, Step is 1 minutes
Guard Timer	500 <10-2000> milliseconds Default:500 milliseconds, Step is 10 milliseconds
HoldOff Timer	0 <0-10000> milliseconds Default:0 milliseconds, Step is 100 milliseconds
<input type="button" value="Apply"/> <input type="button" value="Cancel"/>	

SW6 (Sub Ring 2) WEB configuration as shown:

Ring Adding	
Ring ID	2 <1-255>
Ring Type	sub-ring
Node Type	rpl-neighbour
Protocol Vlan	2 <1-4094>
East Port	GE/3
West Port	GE/4
RPL Port	West Port
Belong Major ring	none
Virtual Channel	with
WTR Timer	1 <1-12> minutes Default:1 minutes, Step is 1 minutes
Guard Timer	500 <10-2000> milliseconds Default:500 milliseconds, Step is 10 milliseconds
HoldOff Timer	0 <0-10000> milliseconds Default:0 milliseconds, Step is 100 milliseconds
<input type="button" value="Apply"/> <input type="button" value="Cancel"/>	

The information in this document is subject to change without notice. Fiberroad has made all effects to ensure the accuracy of the information, but all information in this document does not constitute any kind of warranty. If you have any questions please feel free to contact to us.

Fiberroad Technology Co., Ltd

www.fiberroad.com

Sales Support: sales@fiberroad.com

Technical Support: support@fiberroad.com

Service Support: service@fiberroad.com

