



L2+ Managed Ethernet Switches

FR-7M3208F • FR-7M3208FP • FR-7M3208FBT

Industrial L2+ Managed 8-port 10/100/1000Base-TX (Non-PoE/PoE+/PoE++) + 2-port 100/1000Base-SFP + 2-port Optical Fiber Bypass Switch with Redundant DC Power Inputs

Product Data Sheet

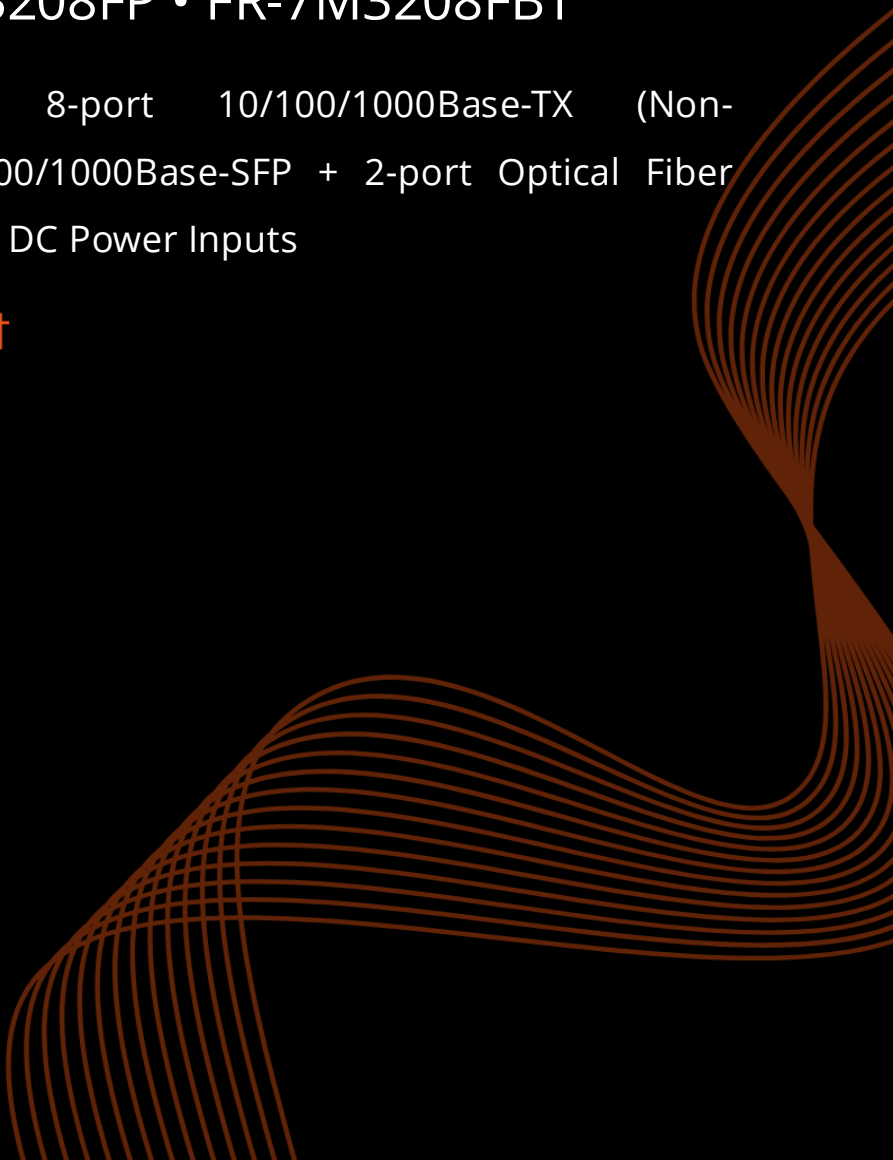

FR-7M3208F • FR-7M3208FP • FR-7M3208FBT



Main Features

- 8x10/100/1000BASE-T Gigabit Ethernet RJ45
- 2x1000Base-X Optical Fiber Bypass
- Optionally support IEEE 802.3 af/at/bt Power Over Ethernet Standard
- Full gigabit L2+ management, easy to manage the network by CLI/WebGUI/NMS.
- Build up a redundant industrial network with STP/RSTP/MSTP/ERPSv2
- Port-based VLAN, IEEE 802.1Q VLAN, and GVRP to ease network planning
- Traffic Classification Based on IEEE 802.1p, CoS, WRR, and Strict Mode
- SNMPv1/v2c/v3 for different levels of network management
- Wide operating temperature range -40 to 75°C (-40 to 167°F)
- All-aluminum Case, Compact and Fanless Design

Overview

Experience unparalleled performance with the Layer 2+ Plus Managed Industrial Ethernet Switch, designed specifically for demanding industrial environments. Engineered for exceptional stability and reliability, this switch ensures seamless Ethernet transmission in factories, outdoor settings, and harsh conditions. Its robust construction withstands the rigors of industrial applications while delivering advanced management features that facilitate optimal network control. Elevate your operational efficiency and safeguard your critical data communications with a solution that has consistently proven its mettle across various sectors. Invest in enduring quality—choose the Layer 2+ Plus Managed Industrial Ethernet Switch for your networking needs.

Engineered for reliability in the most demanding industrial environments, the Layer 2+ Plus Managed Industrial Ethernet Switch seamlessly integrates dual power input design to ensure uninterrupted connectivity. Enclosed in a rugged IP40-rated housing that can be easily mounted on DIN rails or walls, it excels in harsh settings where durability and uptime are critical. With its exceptional operating temperature range of -40 to 75°C, this switch is built to withstand extreme conditions.

Hardware Specifications			
Product	FR-7M3208F	FR-7M3208FP	FR-7M3208FBT
Copper Ports	8x10/100/1000BASE-T RJ45 Auto-MDI/MDI-X (Port 1-8)		
Fiber Ports	\		
Console	1x RJ45-to-RS232 Serial Port(115200)		
Bypass Interface	Connector	Default: 2 x 1000BASE-X Simplex ST (Port 9 & 10); SC/LC/FC connector optional	
	Bypass Optic Mode, Wavelength, Distance	Port 9: T1310/R1550nm 20km Port 10: T1550/R1310nm 20km (Default)	
	Bypass Return Loss	Multimode: >50dB;Singlemode: >35dB	
	Bypass Insertion Loss	Typical: 1.0dB; Max: 1.5dB	
	Bypass Switching Time	< 8ms	
Connector	1 removable 6-contact terminal blocks Pin 1/2 for Power 1, Pin 3/4 for Power 2, Pin 5/6 for fault alarm		
Alarm	One relay output for power failure, Alarm relay current carry ability: 1A@24V DC		
RAM	128Mbyte		
FLASH	32MByte		
Reset Button	<5 sec: System Reboot; >10 sec: Factory Default		
Surge Protection	±6kV DC, ±4kV RJ45	±6kV DC, ±6kV RJ45	
Enclosure	IP40 aluminum case		
Installation	DIN-Rail and Wall-mount		
Dimension	138 x 108 x 49mm		
Weight	7000g(Bare weight), 850g(With package)		
Switching			
Switch Architecture	Store-and-Forward		
Switch Fabric	36Gbps/non-blocking		
Forwarding Rate	11.9Mpps(64-byte packet size)		
Packet Buffer Size	4 Mbits		
Maximum Packet Length	10K bytes		
MAC Address Table	8K entries, automatic source address learning and aging		
Flow Control	IEEE 802.3x pause frame for full duplex, Back pressure for half duplex		
PoE & Power Supply			
PoE Ports	\	Port 1 to 8 IEEE802.3 af/at	Port 1 to 8 IEEE802.3 af/at/bt
PoE Power Supply Type	\	End-span	End-span
Power Supply Pin	\	1/2(+), 3/6(-)	1/2(+), 3/6(-) or 4/5(+), 7/8(-)
Max Power Per Port	\	30W	90W
Input Voltage	DC9-56V	DC48-56V	DC52-56V
Power Consumption	10 Watts Max (without PoE load)		
PoE Power Budget	\	240W maximum (Depending on power input)	240W maximum (Depending on power input)

Environmental	
Operating Temperature	-40°C~75°C (-40 to 167 °F)
Storage Temperature	-40°C~85°C (-40 to 185 °F)
Operating Humidity	5%~95% (non-condensing)
MTBF	907,476 hours @ Telcordia SR-332 Standard
Heat Dissipation	34 BTU/h (non-PoE mode) 853 BTU/h (with 240W PoE load)
Cooling	Passive Cooling, Fanless Design
Noise Level	0 dBA
Software Features	
Port Configuration	Port(Admin Status) disable/enable Copper Port: Auto-negotiation 10/100/1000Mbps full and half duplex mode selection Fiber Port: 100M/1000M speed selection Flow Control disable/enable Power saving(EEE) disable/enable Each port description
Port Status	Display each ports' speed duplex mode, link status, flow control status, auto negotiation status, Fiber Port Information, Port Traffic
Port Mirroring	Source Ingress/ Egress Port/ Both, Many-to-1 monitor
VLAN	Up to 4K VLAN groups, out of 4094 VLAN IDs IEEE 802.1Q tag-based VLAN IEEE 802.1AD Q-in-Q tunneling(Double VLAN) GVRP(Generic VLAN Registration Protocol)
Link Aggregation	IEEE 802.3ad LACP/Static trunk Supports 6 trunk groups with 4 ports per trunk
Spanning Tree Protocol	IEEE 802.1D Spanning Tree Protocol IEEE 802.1w Rapid Spanning Tree Protocol IEEE 802.1s Multiple Spanning Tree Protocol
Multicast	Dynamic/Static Multicast groups IGMP Snooping v1,2,3 Port-based IGMP Snooping Fast Leave GMP Querier
Rate Limitation	Per Port Rate Limitation Ingress: 16-1000000 kbps/Egress: 16-1000000 kbps
Ring	ITU-T G.8032 ERPS, Recovery time < 10ms
QoS	Traffic classification based, strict priority and WRR 8-level priority for switching -Port number -802.1p priority -802.1Q VLAN tag -DSCP/TOS field in IP Packet
ACL	IP-based ACL/MAC-based ACL ACL based on: -MAC Address -IP Address -Ethertype -Protocol Type -VLAN ID -DSCP -802.1p Priority
Security	Port Security Static MAC address IEEE 802.1x port-based network access control RADIUS authentication DHCP Snooping, DHCP option 82

PoE Management Functions

PoE System Management	PoE Port status monitoring Total PoE power budget control PoE usage threshold and temperature threshold PoE port Priority PoE mode(PoE/PoE+/PoE++) PD reboot(Zero Traffic Duration)
PoE Schedule	Absolute/Periodic Mode

Serial Management Functions

Serial Protocol	TCP Server/Client, UDP, Modbus ASCII TCP Server/Client, Modbus RTU Server/Client
Interconnection	Data Bits, Parity, Stop Bits Configuration
Serial Statistics	Bytes and Packets Statistics

Layer 3 Functions

IP Interfaces	Max. 8 VLAN interfaces
Routing Table	Max.32 routing entries
Routing	IPv4 software static routing

Management

Basic Management Interface	Console; Telnet; Web browser; SNMPv1/v2c
Secure Management Interface	SSHv2, TLSv1.2, SNMPv3
System Management	Firmware Upgrade by HTTP protocol through Ethernet network Configuration upload/download through HTTP Remote syslog, System log LLDP protocol, Sntp PREVIEW NMS Alarm(Relay, Led, Temperature, Trap, Power)

LED	State	Description
PWR (P1&P2)	ON	Power is being supplied
	OFF	Power is not being Supplied.
RUN	Blinking	The system is running well
Link/ACT (1-10)	ON	Port connection is active
	Blinking	Data transmitted
	OFF	Port connection is not active
ALM	ON	Has alarm information
	OFF	No alarm information

Regulatory & Warranty

ISO	Manufactured in ISO-9001 facility
Safety	IEC62368-1:2020+A11:2020
EMI	FCC Part 15B Class A, IEC 61000-3-2
EMS	IEC61000-4-2 ESD: Contact:±8kV, Air:±15kV IEC61000-4-5 Surge: Power: ±6kV; RJ45:±4kV/±6kV(PoE)
Shock	IEC 60068-2-27
Free Fall	IEC 60068-2-32
Vibration	IEC 60068-2-6
Environmental	RoHS 2011/65/EU Annex II(EU)
Warranty	5 Years, Details See: https://fiberroad.com/warranty

Package Contents

Device	1 x Industrial Ethernet Switch
Cable	1 x DB9 female to RJ45
Installation Kit	1 x DIN-Rail Clip
Documentation	1 x Quick installation guide 1 x Warranty card

Dimensions Unit: mm

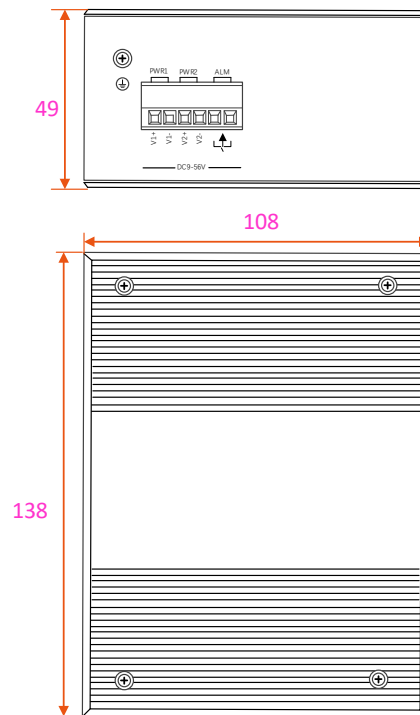

Ordering Information

Available Model	Description	Input Voltage	Operating Temp.
FR-7M3208F	Industrial L2+ Managed 8-port 10/100/1000Base-TX + 2-port 100/1000Base-SFP + 2-port Optical Fiber Bypass Switch with Redundant DC Power Inputs	DC9-56V	-40 to +75°C
FR-7M3208FP	Industrial L2+ Managed 8-port 10/100/1000Base-TX (PoE+) + 2-port 100/1000Base-SFP + 2-port Optical Fiber Bypass Switch with Redundant DC Power Inputs	DC9-56V	-40 to +75°C
FR-7M3208FBT	Industrial L2+ Managed 8-port 10/100/1000Base-TX (PoE++) + 2-port 100/1000Base-SFP + 2-port Optical Fiber Bypass Switch with Redundant DC Power Inputs	DC9-56V	-40 to +75°C

Optional Accessories (to be purchased separately)

Power Supply

FR-I-60-24	DIN-rail 24 VDC power supply with 60W/0.6A, 85 to 264 VAC, or 120 to 370 VDC input, -20 to 70°C operating temperature
FR-I-120-48	DIN-rail 48-58V VDC power supply with 120W/1.2A, , 85 to 264 VAC, or 120 to 370 VDC input, -20 to 70°C operating temperature
FR-I-240W-48	DIN-rail 48-55V VDC power supply with 240W/2A, , 85 to 264 VAC, or 120 to 370 VDC input, -20 to 70°C operating temperature
FR-I-480W-48	DIN-rail 48-55V VDC power supply with 480W/4A, , 85 to 264 VAC, or 120 to 370 VDC input, -20 to 70°C operating temperature

SFP Optical Transceiver

(S)=SFP Option Please select your SFP on our SFP Modules page for details.

Shipping

Model No.	FR-7M3208F	FR-7M3208FP/FR-7M3208FBT
Classification Codes	HS Code: 851762	
	HTS: 8517.62.00	
NDA Compliant	Yes	
Individual Gross Weight	0.85kg	0.9kg
Individual Package Dimension	201x171x73mm	
Package Quantity	20 Units	
Package Gross Weight	18kg	18.7kg
Package Dimension	422x385x375mm	

Precautions

To prevent equipment damage or personal injury caused by improper operation, please observe the following precautions:

- ❖ Turn off the power before installation. Wear an anti-static wrist strap and ensure proper skin contact to prevent electrostatic discharge (ESD) damage.
- ❖ Ensure the power supply voltage matches the voltage specified on the switch.
- ❖ Before powering on the switch, verify that the power circuit is not overloaded to avoid abnormal operation or equipment damage.
- ❖ Do not open the chassis while the switch is operating. To avoid the risk of electric shock, do not disassemble the device.
- ❖ Disconnect the power before cleaning. Do not use a wet cloth or liquid cleaners.
- ❖ When installing in a rack, mount equipment from bottom to top to prevent overloading.
- ❖ Do not place heavy objects on the switch.

Specifications are subject to change without notice. Fiberroad Technology Co., Ltd. makes no warranties, either expressed or implied, regarding the information contained herein. Please contact us for the latest product information.